

ICOS Technology \_ Min rating 5Amp  
 Max load 2 x 27 watt on any output  
 HW Ver 4.3.0 SW Ver 5.3.3 2014-04-30  
 LFOD Not in use for Camaro

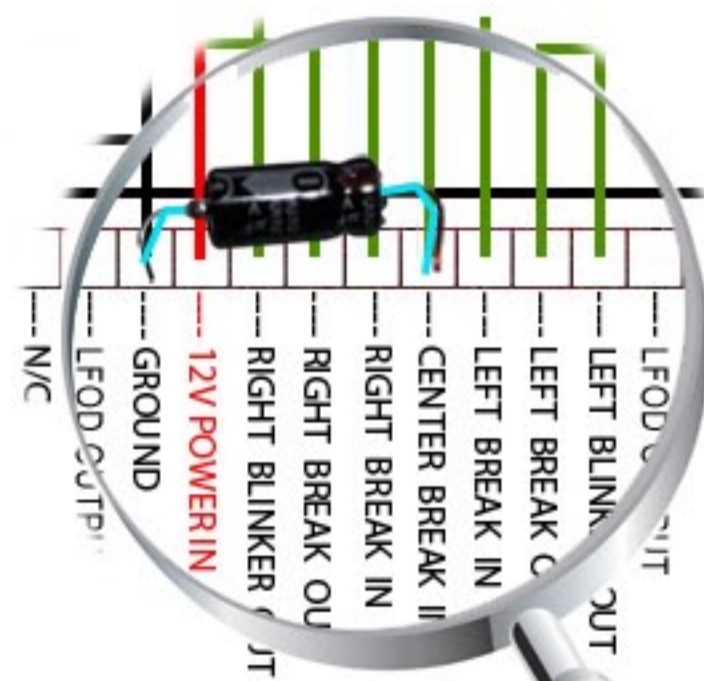

On some models we have noticed that if your blinker is on and you hit the brake it can interfere with the blinker. This capacitor solves that.

Just connect it between "Ground" and "Center brake In" Notice Ground on capacitor.

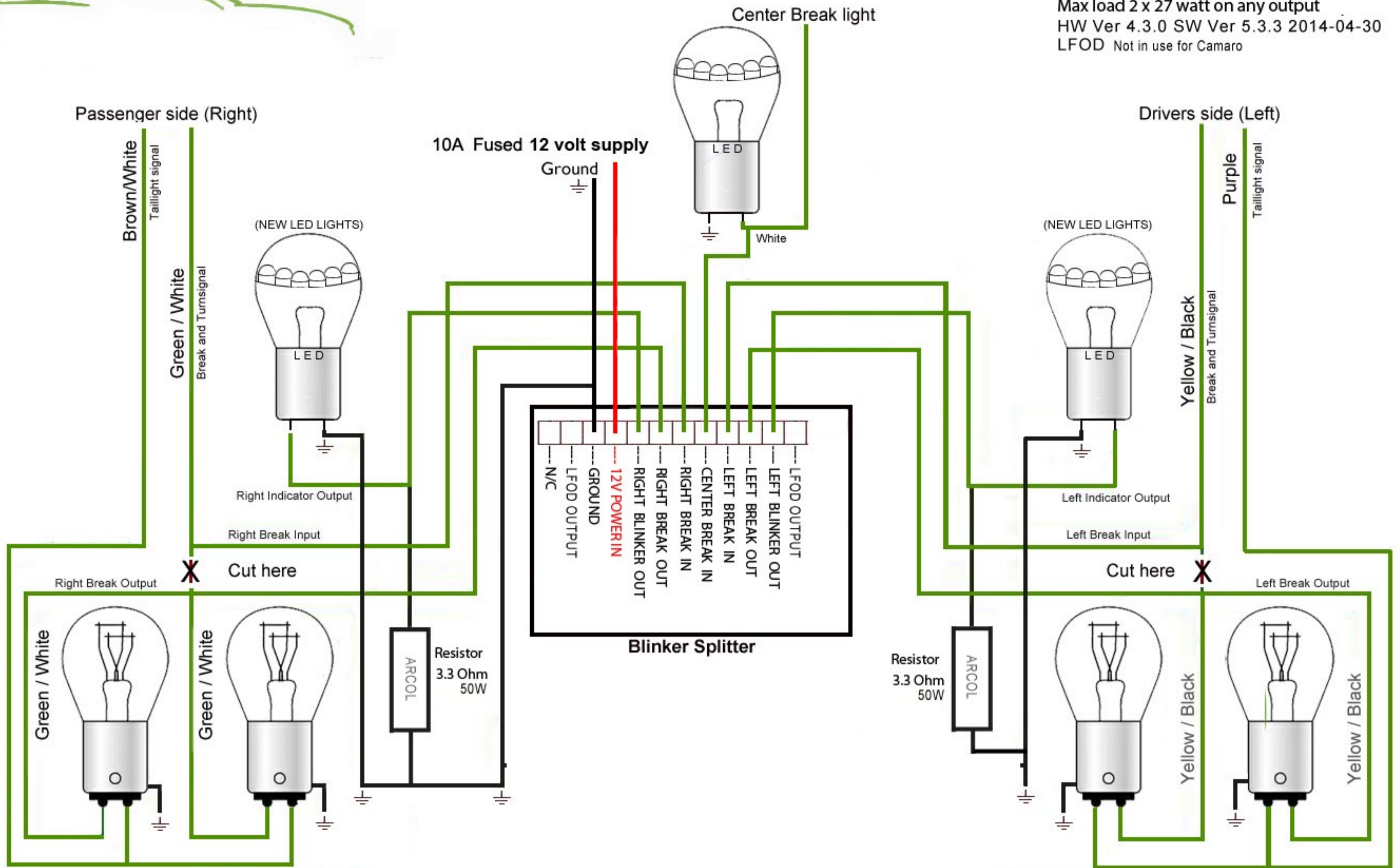